

Ø.25
MOUNTING HOLES
TYP 2 PL

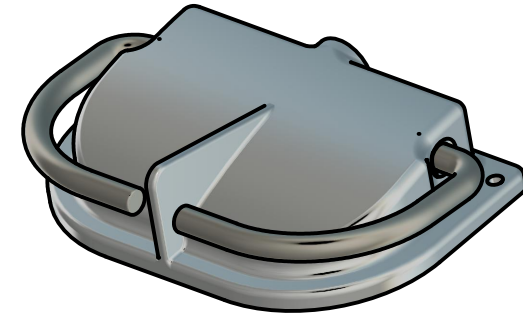

SCALE 1:3

1. Polished aluminum housing with plated steel pedals.
2. ½" NPTF connector hole standard for cable strain relief fittings. Other connector holes available on request.
3. No exterior springs! Two torsion springs located inside foot switch.
4. Two mounting holes.
5. Capable of handling up to 12/3 cable or .50" O.D.
6. .187" x .020" quick connect terminals.
7. Wide target area for foot operation.
8. Long life snap switch.
9. #8 grounding screw is provided.
10. Skid-resistant elastomeric base pad.
11. UL listed to U.S. and Canadian safety standards.
12. NEMA and IEC Ingress Protection (IP) rated.
13. Single foot switch model available without barrier.
14. Integrated barrier.
15. Low profile design.
16. Buna-N O-Ring and Buna-N gasket seals.
17. Numerous cord strain reliefs available for your special requirements.

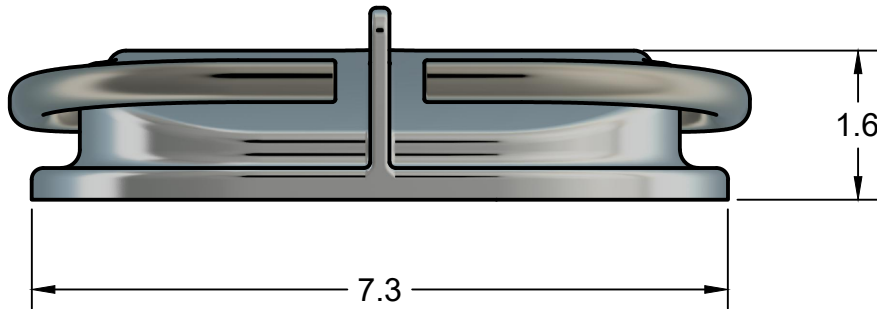
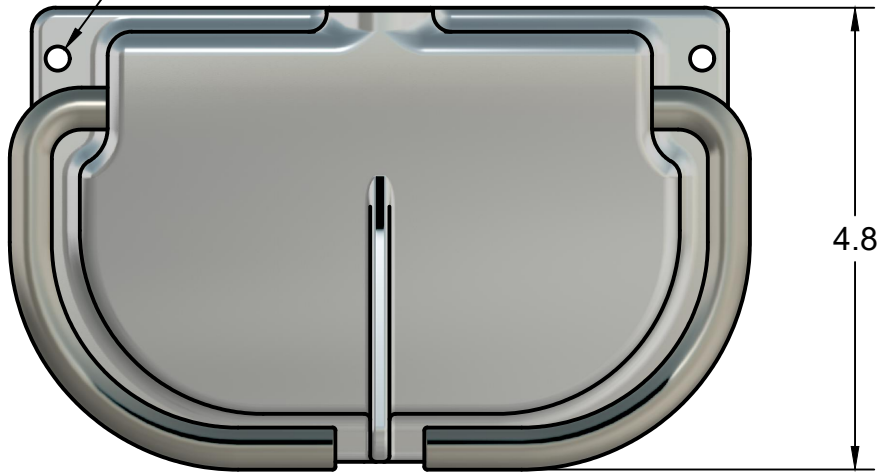

UNLESS STATED, TOLERANCES ARE:

.XX +/- .015
.XXX +/- .005

ALL DIMENSIONS ARE IN INCHES

DRAWING NUMBER

Series 220 Sales Drawing
WS220-001

THIS DOCUMENT IS THE PROPERTY OF CONNTROL INTERNATIONAL, INC. AND IS NOT TO BE DISCLOSED, REPRODUCED, IN WHOLE OR IN PART, OR USED FOR MANUFACTURE FOR ANYONE OTHER THAN CONNTROL INTERNATIONAL, INC. WITHOUT ITS WRITTEN CONSENT.

APPROVED JPB	8/14/2024	MATERIAL		REV
CHECKED RB	8/14/2024	N/A		
DRAWN JPB	8/14/2024	SCALE 1:2	SIZE A	SHEET 1/1